

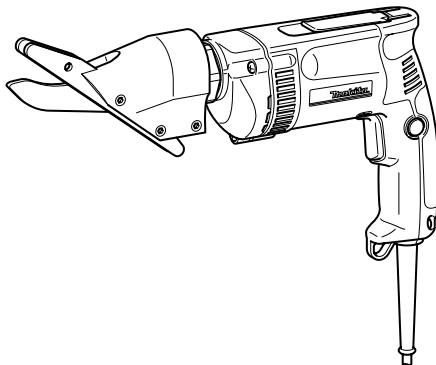

INSTRUCTION MANUAL

# Cement Shear

JS8000



007430

 DOUBLE INSULATION

**⚠ WARNING:**

For your personal safety, READ and UNDERSTAND before using.  
SAVE THESE INSTRUCTIONS FOR FUTURE REFERENCE.

## ENGLISH SPECIFICATIONS

Model		JS8000
Max. cutting capacities	Fiber cement material	8 mm
Strokes per minute (min <sup>-1</sup> )		0 - 2,500
Overall length		346 mm
Net weight		2.2 kg
Safety class		II/II

- Due to our continuing programme of research and development, the specifications herein are subject to change without notice.
- Specifications may differ from country to country.
- Weight according to EPTA-Procedure 01/2003

END201-5

ENG218-2

### Symbols

The following show the symbols used for the equipment. Be sure that you understand their meaning before use.



- Read instruction manual.



- DOUBLE INSULATION



- Only for EU countries

Do not dispose of electric equipment together with household waste material! In observance of European Directive 2002/96/EC on waste electric and electronic equipment and its implementation in accordance with national law, electric equipment that have reached the end of their life must be collected separately and returned to an environmentally compatible recycling facility.

ENE065-1

### Intended use

The tool is intended for cutting fiber cement material only.

ENF002-1

### Power supply

The tool should be connected only to a power supply of the same voltage as indicated on the nameplate, and can only be operated on single-phase AC supply. They are double-insulated in accordance with European Standard and can, therefore, also be used from sockets without earth wire.

ENG102-3

### Noise

The typical A-weighted noise level determined according to EN60745:

- Sound pressure level ( $L_{pA}$ ) : 82 dB(A)
- Sound power level ( $L_{WA}$ ) : 93 dB(A)
- Uncertainty (K) : 3 dB(A)

### Wear ear protection

### Vibration

The vibration total value (tri-axial vector sum) determined according to EN60745:

- Work mode : cutting sheet metal
- Vibration emission ( $a_h$ ) : 4.5 m/s<sup>2</sup>
- Uncertainty (K) : 1.5 m/s<sup>2</sup>

ENH101-13

### For European countries only

### EC Declaration of Conformity

**We Makita Corporation as the responsible manufacturer declare that the following Makita machine(s):**

Designation of Machine:  
Cement Shear

Model No./ Type: JS8000  
are of series production and

### Conforms to the following European Directives:

98/37/EC until 28th December 2009 and then with  
2006/42/EC from 29th December 2009

And are manufactured in accordance with the following standards or standardised documents:

EN60745

The technical documentation is kept by our authorised representative in Europe who is:

Makita International Europe Ltd,  
Michigan, Drive, Tongwell,  
Milton Keynes, MK15 8JD, England

30th January 2009

000230

Tomoyasu Kato  
Director

Makita Corporation  
3-11-8, Sumiyoshi-cho,  
Anjo, Aichi, JAPAN

## General Power Tool Safety

### Warnings

**⚠ WARNING** Read all safety warnings and all instructions. Failure to follow the warnings and instructions may result in electric shock, fire and/or serious injury.

### Save all warnings and instructions for future reference.

The term "power tool" in the warnings refers to your mains-operated (corded) power tool or battery-operated (cordless) power tool.

#### Work area safety

1. **Keep work area clean and well lit.** Cluttered or dark areas invite accidents.
2. **Do not operate power tools in explosive atmospheres, such as in the presence of flammable liquids, gases or dust.** Power tools create sparks which may ignite the dust or fumes.
3. **Keep children and bystanders away while operating a power tool.** Distractions can cause you to lose control.

#### Electrical safety

4. **Power tool plugs must match the outlet. Never modify the plug in any way. Do not use any adapter plugs with earthed (grounded) power tools.** Unmodified plugs and matching outlets will reduce risk of electric shock.
5. **Avoid body contact with earthed or grounded surfaces such as pipes, radiators, ranges and refrigerators.** There is an increased risk of electric shock if your body is earthed or grounded.
6. **Do not expose power tools to rain or wet conditions.** Water entering a power tool will increase the risk of electric shock.
7. **Do not abuse the cord. Never use the cord for carrying, pulling or unplugging the power tool. Keep cord away from heat, oil, sharp edges or moving parts.** Damaged or entangled cords increase the risk of electric shock.
8. **When operating a power tool outdoors, use an extension cord suitable for outdoor use.** Use of a cord suitable for outdoor use reduces the risk of electric shock.
9. **If operating a power tool in a damp location is unavoidable, use a residual current device (RCD) protected supply.** Use of an RCD reduces the risk of electric shock.
10. **Use of power supply via a RCD with a rated residual current of 30mA or less is always recommended.**

#### Personal safety

11. **Stay alert, watch what you are doing and use common sense when operating a power tool. Do not use a power tool while you are tired or under the influence of drugs, alcohol or medication.** A moment of inattention while operating power tools may result in serious personal injury.
12. **Use personal protective equipment. Always wear eye protection.** Protective equipment such as dust mask, non-skid safety shoes, hard hat, or hearing protection used for appropriate conditions will reduce personal injuries.
13. **Prevent unintentional starting. Ensure the switch is in the off-position before connecting to power source and/or battery pack, picking up or carrying the tool.** Carrying power tools with your finger on the switch or energising power tools that have the switch on invites accidents.
14. **Remove any adjusting key or wrench before turning the power tool on.** A wrench or a key left attached to a rotating part of the power tool may result in personal injury.
15. **Do not overreach. Keep proper footing and balance at all times.** This enables better control of the power tool in unexpected situations.
16. **Dress properly. Do not wear loose clothing or jewellery. Keep your hair, clothing, and gloves away from moving parts.** Loose clothes, jewellery or long hair can be caught in moving parts.
17. **If devices are provided for the connection of dust extraction and collection facilities, ensure these are connected and properly used.** Use of dust collection can reduce dust-related hazards.

#### Power tool use and care

18. **Do not force the power tool. Use the correct power tool for your application.** The correct power tool will do the job better and safer at the rate for which it was designed.
19. **Do not use the power tool if the switch does not turn it on and off.** Any power tool that cannot be controlled with the switch is dangerous and must be repaired.
20. **Disconnect the plug from the power source and/or the battery pack from the power tool before making any adjustments, changing accessories, or storing power tools.** Such preventive safety measures reduce the risk of starting the power tool accidentally.
21. **Store idle power tools out of the reach of children and do not allow persons unfamiliar with the power tool or these instructions to operate the power tool.** Power tools are

dangerous in the hands of untrained users.

22. **Maintain power tools. Check for misalignment or binding of moving parts, breakage of parts and any other condition that may affect the power tool's operation. If damaged, have the power tool repaired before use.** Many accidents are caused by poorly maintained power tools.
23. **Keep cutting tools sharp and clean.** Properly maintained cutting tools with sharp cutting edges are less likely to bind and are easier to control.
24. **Use the power tool, accessories and tool bits etc. in accordance with these instructions, taking into account the working conditions and the work to be performed.** Use of the power tool for operations different from those intended could result in a hazardous situation.

#### Service

25. **Have your power tool serviced by a qualified repair person using only identical replacement parts.** This will ensure that the safety of the power tool is maintained.
26. **Follow instruction for lubricating and changing accessories.**
27. **Keep handles dry, clean and free from oil and grease.**

GEB032-2

## CEMENT SHEAR SAFETY WARNINGS

1. **Hold the tool firmly.**
2. **Secure the workpiece firmly.**
3. **Keep hands away from moving parts.**
4. **Edges and chips of the workpiece are sharp. Wear gloves. It is also recommended that you put on thickly bottomed shoes to prevent injury.**
5. **Do not put the tool on the chips of the workpiece. Otherwise it can cause damage and trouble on the tool.**
6. **Do not leave the tool running. Operate the tool only when hand-held.**
7. **Always be sure you have a firm footing. Be sure no one is below when using the tool in high locations.**
8. **Do not touch the blade or the workpiece immediately after operation; they may be extremely hot and could burn your skin.**
9. **Avoid cutting electrical wires. It can cause serious accident by electric shock.**
10. **Some material contains chemicals which may be toxic. Take caution to prevent dust inhalation and skin contact. Follow material supplier safety data.**

11. **Always use the correct dust mask/respirator for the material and application you are working with.**

## SAVE THESE INSTRUCTIONS.

### ⚠WARNING:

**DO NOT let comfort or familiarity with product (gained from repeated use) replace strict adherence to safety rules for the subject product. MISUSE or failure to follow the safety rules stated in this instruction manual may cause serious personal injury.**

## FUNCTIONAL DESCRIPTION

### ⚠CAUTION:

- Always be sure that the tool is switched off and unplugged before adjusting or checking function on the tool.

### Switch action

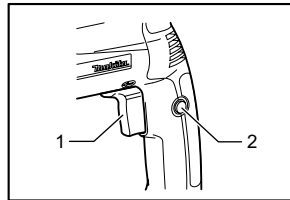

1. Switch trigger
2. Lock button

004668

### ⚠CAUTION:

- Before plugging in the tool, always check to see that the switch trigger actuates properly and returns to the "OFF" position when released.

To start the tool, simply pull the switch trigger. Tool speed is increased by increasing pressure on the switch trigger. Release the switch trigger to stop.

For continuous operation, pull the switch trigger and then push in the lock button.

To stop the tool from the locked position, pull the switch trigger fully, then release it.

### Hook

The hook is convenient for temporary hanging the tool. When using the hook, pull it out in "A" direction and then push it in "B" direction to secure in place.

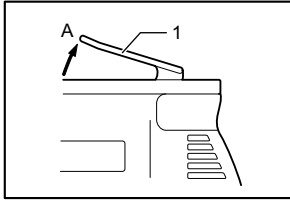

004676

1. Hook

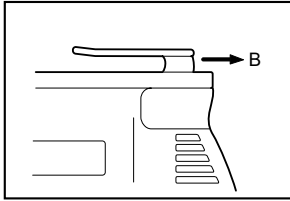

004677

When not using the hook, return it back to its initial position by following the above procedures in reverse.

## ASSEMBLY

### ⚠ CAUTION:

- Always be sure that the tool is switched off and unplugged before carrying out any work on the tool.

### Replacement of blades

### ⚠ CAUTION:

- Never remove the blades with bare hands. Wear gloves. Otherwise it can cause injury.

### Removing cutting head

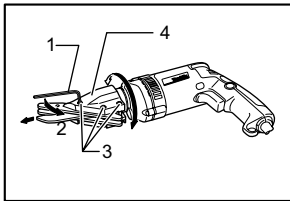

007431

- Hex wrench
- Loosen
- Screws
- Cutting head

Use the hex wrench to loosen the three screws which secure the cutting head. Pull the cutting head straight out to remove it with turning it left and right alternately.

### Removing shear blades

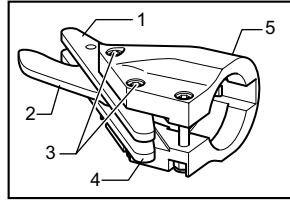

007432

- Side blade
- Center blade
- Screws
- Side blade
- Cutting head

Remove the two screws (middle and front) which hold the cutting head. When removing the middle screw, be careful not to lose the spacer. Then the blades can be removed easily. When removing the blades, hold the blades, the spacer and the pivot sleeve so that they do not fall from the cutting head.

### Installing shear blades

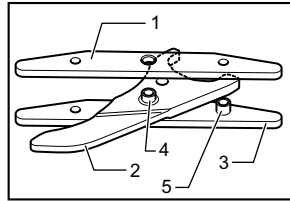

007433

- Side blade
- Center blade
- Side blade
- Pivot sleeve
- Spacer

Install the spacer and the pivot sleeve and tighten the three screws after inserting the center blade, side blades into the cutting head. In this process, the screw heads should be protruding 2 - 3 mm from the cutting head surface.

If you will tighten the screws excessively, the cutting head cannot be installed to the tool.

### NOTE:

- Side blade edge can be used in four ways by repositioning them left-to-right and end-to-end as shown in the figure.

The following describes time and procedure to change blades.

- When the two side blades have rounded about half their width, they can be repositioned left-to-right for new cutting edges.
- When both edges of each side blade have rounded about half their width, reposition them end-to-end for two new cutting edges.
- When all edges have worn down, obtain replacements from Makita authorized or factory service center.
- When side blades are worn out, the center blade should also be replaced.

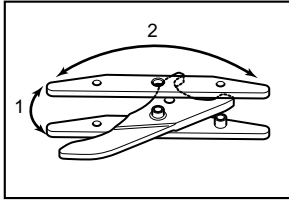

007435

1. Reposition end-to-end
2. Reposition left-to-right

### Installing cutting head

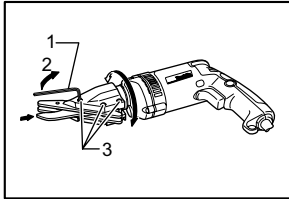

007436

1. Hex wrench
2. Tighten
3. Screws

### ⚠CAUTION:

- Secure the cutting head firmly. Otherwise it can rotate during operation and can cause serious injury.

Insert the cutting head into the tool with turning it left and right alternately. Then tighten the three screws with the hex wrench.

## OPERATION

### ⚠CAUTION:

- This tool is intended for cutting fiber cement material only, with a thickness of 8 mm or less. Do not cut other materials or stack-cut. Doing so will damage the tool and void warranty.
- Wear gloves. Otherwise it can cause injury.

Secure the workpiece firmly. Move the tool forward keeping the side blades flush with the workpiece surface.

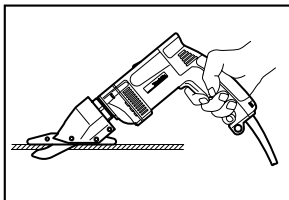

007434

## MAINTENANCE

### ⚠CAUTION:

- Always be sure that the tool is switched off and unplugged before attempting to perform inspection or maintenance.

### Lubrication

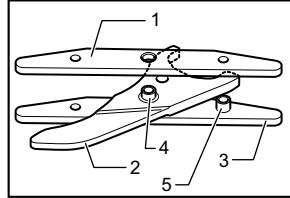

007433

1. Side blade
2. Center blade
3. Side blade
4. Pivot sleeve
5. Spacer

Before operation, lubricate the contact point of the center blade and the side blades. And, also lubricate around the pivot sleeve and the spacer.

To maintain product SAFETY and RELIABILITY, repairs, carbon brush inspection and replacement, any other maintenance or adjustment should be performed by Makita Authorized Service Centers, always using Makita replacement parts.

## ACCESSORIES

### ⚠CAUTION:

- These accessories or attachments are recommended for use with your Makita tool specified in this manual. The use of any other accessories or attachments might present a risk of injury to persons. Only use accessory or attachment for its stated purpose.

If you need any assistance for more details regarding these accessories, ask your local Makita Service Center.

- Center blade
- Side blades
- Hex wrench



Makita Corporation Anjo, Aichi, Japan