

Standard equipment

Rotary Hammer

Model HP2050, HP2050F	Part No.
Grip 36 complete	152521-9
Depth Gauge (Stopper pole)	324219-0
Drill chuck	192877-8
Chuck key	763432-9
Plastic carrying case	824650-5

Model HP2051, HP2051F	Part No.
Grip 36 complete	152521-9
Depth Gauge (Stopper pole)	324219-0
Keyless drill chuck	192664-5
Plastic carrying case	824650-5

Items of standard equipment may differ from country to country.

Optional accessories

Rotary Hammer

Tungsten carbide-tipped bit



Bit diameter (mm)	Overall length (mm)	Part No.
5.0	70	791027-8
6.5	80	791092-7
7.5	90	791028-6
8.0	120	711057-3
8.5	100	791008-2
8.5	180	711026-4
9.5	120	711058-1
10.5	120	711059-9
11.0	120	791009-0
12.5	120	711060-4
14.0	150	791029-4
14.0	180	711027-2
14.0	300	711028-0
16.0	220	791036-7
19.0	220	791037-5

Blow-out bulb

(For blowing chips and dust from drilled holes)



Part No.
765009-6

Type 43 drill stand



Part No.
JPA122190

Hole saw

With high quality carbide tips brazed on to the cutting edge, high speed drilling of plates up to 4 mm is possible and no coolant is required. Carbide tips are random-spaced to reduce chattering. (Keep rotation mode)



Bit diameter (mm)	Shank dia. (mm)	Part No.
16	6	B-00898
18		B-00907
20		B-00913
21		B-00929
22	10	B-00935
25		B-00941
27		B-00957
28		B-00963
30		B-00979
32		B-00985
35		B-00991
38		B-01002
40		B-01018
45		B-01024
48	13	B-01030
50		B-01046
55		B-01052
60		B-01068
65		B-01074
70		B-01080
75		B-01096
80		B-01105
85		B-01111
90		B-01127

Center drill

For hole saw



Application	For hole saw bit diameter (mm)	Part No.
Steel, stainless steel, copper, aluminum, etc.	16 — 55	B-01177
	60 — 90	B-01183
FRP, resin, etc.	16 — 55	B-01199
	60 — 90	B-01208

Metal borer

With high quality carbide tips brazed on to the cutting edge, high speed drilling of plates up to 12 mm is possible and no coolant is required. Carbide tips are random-spaced to reduce chattering. (Keep rotation mode)



Bit diameter (mm)	Part No.
14	B-02266
14.5	B-02272
15	B-02288
16	B-02294
17	B-02303
18	B-02319
19	B-02325
20	B-02331
21	B-02347
22	B-02353
23	B-02369
24	B-02375
25	B-02381
26	B-02397
27	B-02406
28	B-02412
29	B-02428
30	B-02434
31	B-02440
32	B-02456
33	B-02462
34	B-02478
35	B-02484

Shank assembly

(For metal borer)



Type	Shank dia.	Part No.
Center drill type	10 mm	B-02490
Center pin type	13 mm	B-02509



A world's leading manufacturer of power tools

- Double Insulation
- Built-in Job Light for Model HP2050F/HP2051F
- Variable Speed
- Mechanical 2-Speed
- Carrying Case
- Reversing
- Torque Limiter

2 Speed Hammer Drills

20 mm (3/4") HP2050F/HP2051F (with LED job light)
HP2050/HP2051



Slimmer and more compact hammer drills, yet loaded with torque limiter!

PHOTO: Model HP2051F

NEW



A world's leading manufacturer of power tools

Extra-low vibration level for reduced operator fatigue!

Performance Data

Note: It may differ under some conditions.

Drilling speed

Work piece : Mortar

When Hammer drilling with : $\phi 8$ mm (5/16") bit.

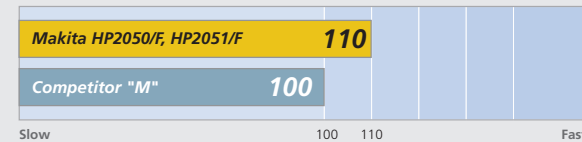

Slow 100 110 Fast

When Hammer drilling with : $\phi 12.5$ mm (1/2") bit.

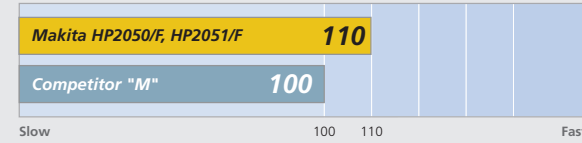

Slow 100 110 Fast

When Hammer drilling with : $\phi 19.0$ mm (3/4") bit.

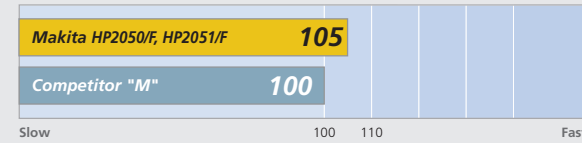

Slow 100 110 Fast

Work piece : Douglas fir (Wood)

When drilling with : $\phi 24$ mm (15/16") Auger bit.

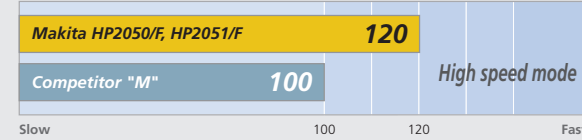

Slow 100 120 Fast

When drilling with : $\phi 36$ mm (1-7/16") Auger bit.

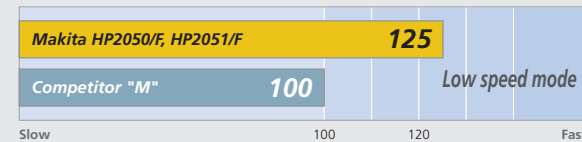

Slow 100 120 Fast

Numbers in chart are relative values when setting competitor "M's" capacity as 100.

2 Speed Hammer Drill 20 mm (3/4")

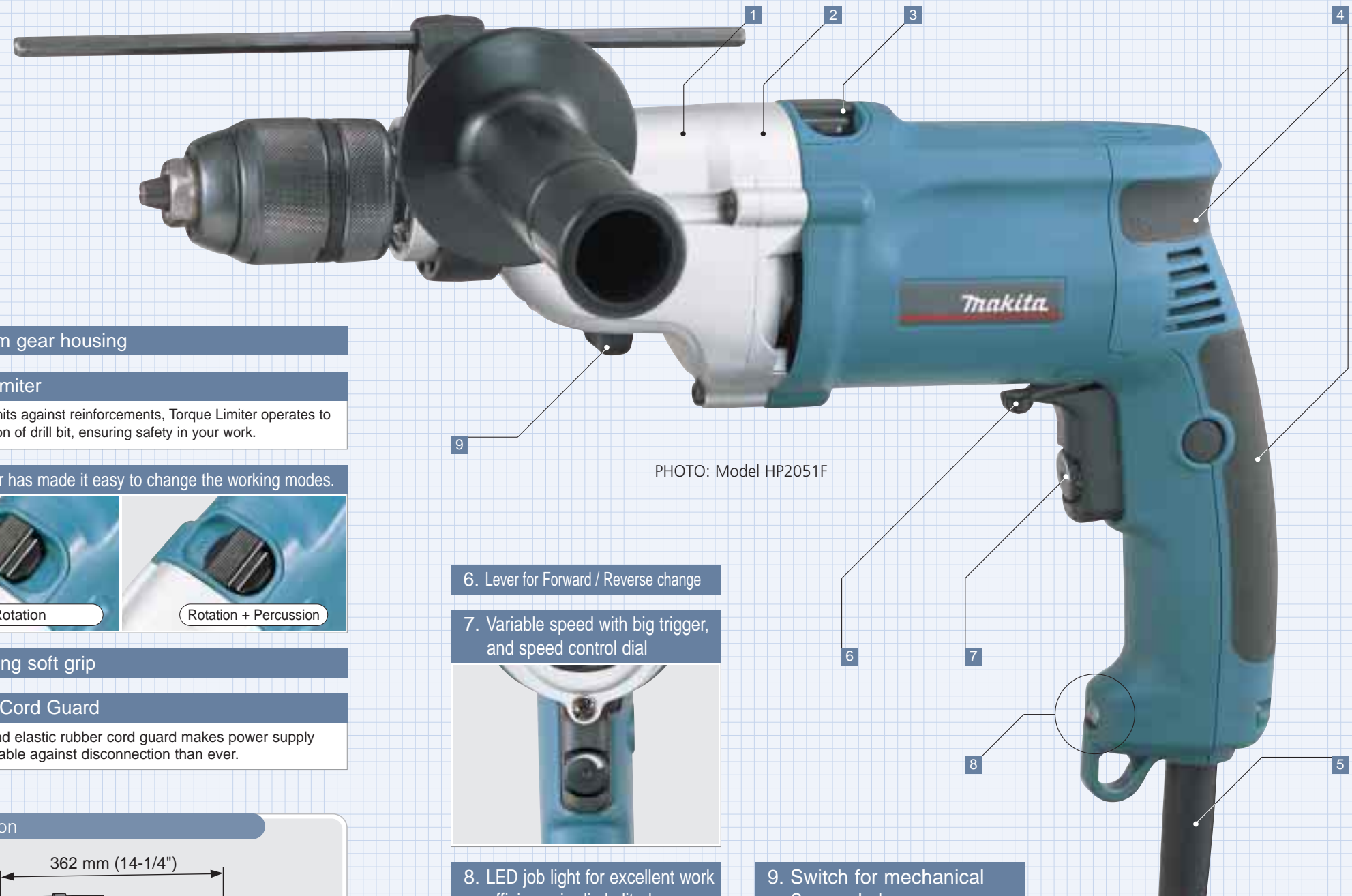

PHOTO: Model HP2051F

1. Aluminum gear housing

2. Torque limiter

When drill bit hits against reinforcements, Torque Limiter operates to stop the rotation of drill bit, ensuring safety in your work.

3. Large lever has made it easy to change the working modes.



4. Palm fitting soft grip

5. Durable Cord Guard

The flexible and elastic rubber cord guard makes power supply cord more durable against disconnection than ever.

6. Lever for Forward / Reverse change

7. Variable speed with big trigger, and speed control dial



8. LED job light for excellent work efficiency in dimly-lit place.



9. Switch for mechanical 2 speed change



Dimension

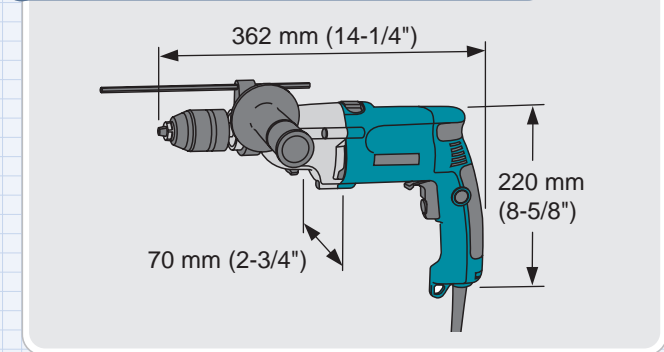

Specifications

Rotary Hammer

Max. capacities

Concrete (TCT. hammer bit)	20 mm (3/4")
Steel	High : 8 mm (5/16") Low : 13 mm (1/2")
Wood	High : 25 mm (1") Low : 40 mm (1-9/16")
Continuous rating Input	720W
No load speed	High : 0 - 2,900 min ⁻¹ (rpm) Low : 0 - 1,200 min ⁻¹ (rpm)
Blows per minute	High : 0 - 58,000 min ⁻¹ (bpm) Low : 0 - 24,000 min ⁻¹ (bpm)
Overall length	362 mm (14-1/4")
Net weight	2.3 kg (5.1 lbs)
Power supply cord	2.5 m (8.2 ft.)

Specifications may differ from country to country.

	Built-in Job Light	Keyless drill chuck
HP2050	No	No
HP2050F	Yes	No
HP2051	No	Yes
HP2051F	Yes	Yes