

Specifications

Impact Wrench

Double Insulation

Variable Speed (TW0200 only)

Reversing

Plastic Carrying Case

	Model TW0200	Model TW0350
Capacities		
Standard bolt	M10 – M16	M12 – M22
High Tensile bolt	M10 – M12	M12 – M16
Square drive	12.7 mm (1/2")	12.7 mm (1/2")
Impact per minute	0 – 2,200 min ⁻¹ (bpm)	2,000 min ⁻¹ (bpm)
Continuous rating		
Input	380 W	400 W
No load speed	0 – 2,200 min ⁻¹ (rpm)	2,000 min ⁻¹ (rpm)
Max. fastening torque	200 N·m (150 ft·lb)	350 N·m (260 ft·lb)
Overall length	251 mm (9-7/8")	282 mm (11-1/8")
Net weight	2.1 kg (4.6 lbs)	2.9 kg (6.4 lbs)
Power supply cord	2.5 m (8.2 ft.)	2.5 m (8.2 ft.)

Specifications may differ from country to country.

Dimension

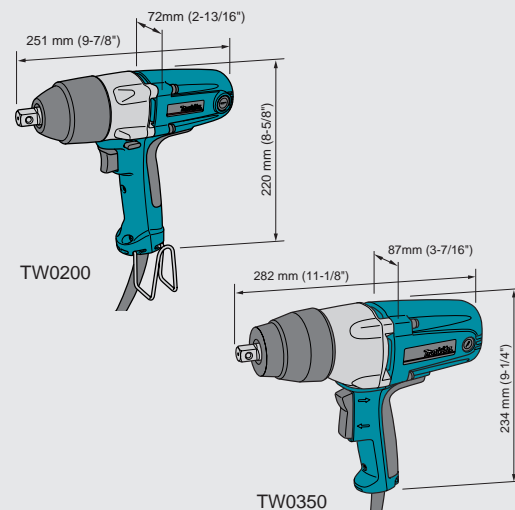

A world's leading manufacturer of power tools

Double Insulation

Variable Speed (TW0200 only)

Reversing

Plastic Carrying Case

Impact Wrench

Model TW0200 / TW0350

New Generation Impact Wrench series



NEW

Standard equipment

Impact Wrench

Plastic carrying case
Socket 24-45

The standard equipment for the tool shown may differ from country to country.

Optional accessories

Impact Wrench

Socket	For Model	A (mm)	L (mm)	Part No.	Extension bar	Universal joint	Bit adapter assembly	Phillips bit	
Square drive 12.7 (mm) (With pin and O ring)	TW0200	17	38	134829-3	(With pin and O ring) For work in narrow places where the socket will not reach.	(With pin and O ring) For use in a limited space where the tool cannot be held in line with the axis of the bolt or nut.	(With pin and O ring)	(3 per pkg.) • Hard type (1 per pkg.)	
		17	52	134830-8					
		19	38	134831-6	L (mm)	Part No.	L (mm) Part No.	Size L (mm) Part No.	
		19	52	134832-4	100	134874-8			84
		19	78	134837-4	L (mm) Part No.	L (mm) Part No.	L (mm) Part No.	L (mm) Part No.	
		21	38	134838-2					84
		21	52	134833-2	84	134877-2	45	784229-3	No.2
		21	78	134839-0	84	134877-2	65	798309-9	
		22	38	134851-0	84	134877-2	65	784230-8	No.3
		22	52	134834-0	84	134877-2	65	798311-2	
	23	38	134840-5	84	134877-2	65	784230-8	No.3	
	23	52	134835-8	84	134877-2	65	798337-4		No.3
	24	45	134841-3	84	134877-2	65	798337-4	No.3	
	24	52	134836-6	84	134877-2	65	798337-4		No.3
	26	50	134842-1	84	134877-2	65	798337-4	No.3	
	26	78	134843-9	84	134877-2	65	798337-4		No.3
	27	50	134844-7	84	134877-2	65	798337-4	No.3	
	27	78	134845-5	84	134877-2	65	798337-4		No.3
	30	50	134846-3	84	134877-2	65	798337-4	No.3	
	30	78	134847-1	84	134877-2	65	798337-4		No.3
32	50	134848-9	84	134877-2	65	798337-4	No.3		
32	78	134849-7	84	134877-2	65	798337-4		No.3	
	TW0350								

Makita Corporation

3-11-8, Sumiyoshi-cho, Anjo, Aichi 446-8502, Japan

PRINTED IN JAPAN Z23084-2 2003-5

Incredibly High Torque / TW0350

Compact body for superior handling / TW0200



TW0200 Max. fastening torque
200 N·m



1. Push button type reverse switch
2. Variable speed switch (TW0200)
3. Toolless detachable belt clip (TW0200)
Can be attached on both left and right sides without any tool!
4. High rigid aluminum internal gear case and hammer case
5. Externally accessible carbon brush for easy replacement
6. Palm fitting soft grip
7. Rocker switch provides easy reversing (TW0350)

TW0350 Max. fastening torque
350 N·m

Fastening Speed

Fastening high tensile bolt M16

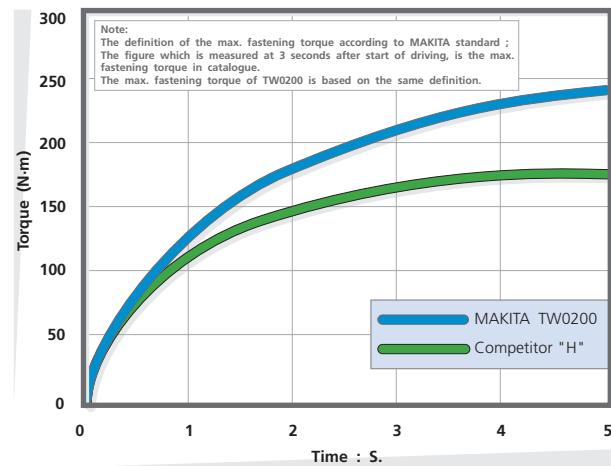

Fastening high tensile bolt M20

